

Smart Posterboard System

Multi-modal Sensing & Analysis

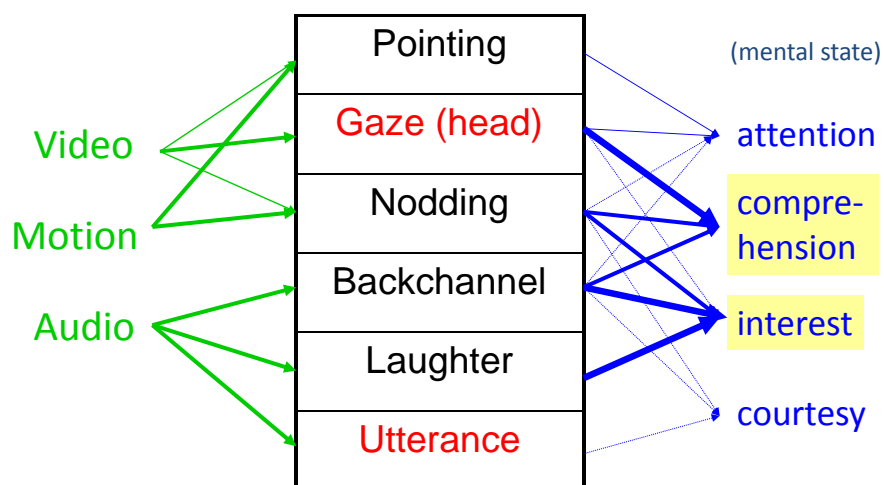

Why Poster Sessions?

- Norm in conferences & open-houses
- Mixture characteristics of lectures and meetings
 - One main speaker, with a small audience
 - Anyone of the audience can take an initiative
- Interactive
 - Real-time feedback by audience
 - including back-channels & nodding
- Multi-modal (truly)
 - Standing & moving
- Real, but controlled (knowledge/familiarity)

Smart Posterboard Demonstration Overview

- **Offline** Diarization & Browser Demo
with 19-channel Microphone Array & 6 Cameras
 - Speech enhancement with **BSSA** (Blind Spatial Subtraction Array)
 - Speaker diarization based on adapted GMM
 - Speaker localization & Gaze (head direction) detection
- **Online tracking using Kinect**
 - Speaker localization & gaze (head direction) detection
 - Speech enhancementLive
Demo

Speech Separation & Enhancement: Blind Spatial Subtraction Array (BSSA)

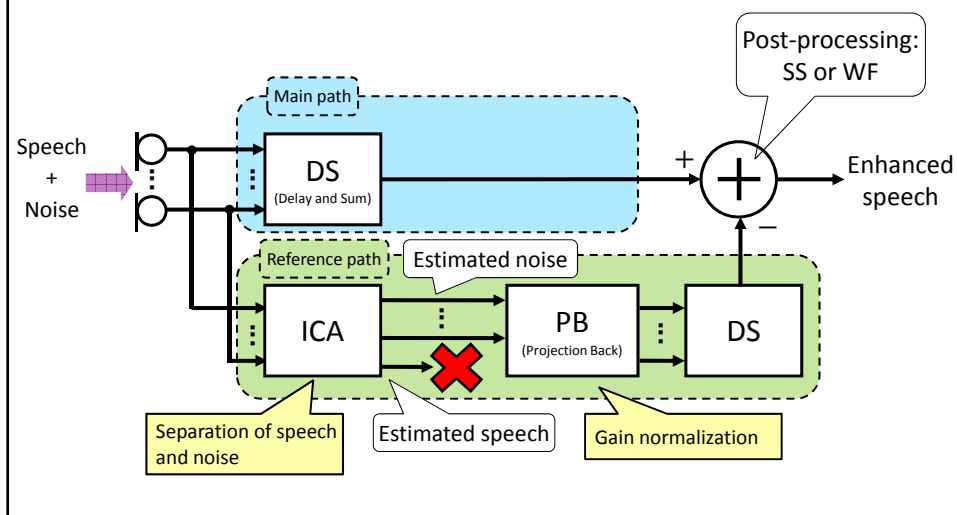

Application Scenario

- Poster session archiving + browser
 - Interaction analysis
 - Visualization and mining
 - Review Q-A afterwards
 - Extract segments people find interesting or difficult to understand
- Automated presentation system
 - Switch slides according to interest and knowledge level
 - Answer questions

Staffs contributed to this Demo.

- Kyoto University:
 - Tony Tung, Hiromasa Yoshimoto, Randy Gomez, Soichiro Hayashi, Yuya Akita, **Tatsuya Kawahara**

- Nara Institute of Science & Technology
 - Kodai Okamoto, Yuji Onuma, Noriyoshi Kamado, Ryoichi Miyazaki, **Hiroshi Saruwatari**

References

1. T.Kawahara, K.Sumii, Z.Q.Chang, and K.Takanashi.
Detection of hot spots in poster conversations based on reactive tokens of audience.
In Proc. INTERSPEECH, pp.3042--3045, 2010.
2. T.Kawahara, Z.Q.Chang, and K.Takanashi.
Analysis on prosodic features of Japanese reactive tokens in poster conversations.
In Proc. Int'l Conf. Speech Prosody, 2010.
3. T.Kawahara, H.Setoguchi, K.Takanashi, K.Ishizuka, and S.Araki.
Multi-modal recording, analysis and indexing of poster sessions.
In Proc. INTERSPEECH, pp.1622--1625, 2008.